

Pos.Nr. Pos.no. Position	Beschreibung Description Désignation	Preisgruppe Price bracket Catégorie de prix	Art.-Nr. Art.no. Réf.	
1	Motor		85093	57
2	Stromabnehmer		85319	39
3	Haftungsatz DC		85622	19
4	Ansatzschraube M 2X5		85669	3
5	Schraube M 2X8		85674	2
6	Schraube 2.2X9.5		85808	2
7	Feder		86202	2
8	Schneckenzahnrad		86490	4
9	Zahnrad		86493	2
10	Kardanschale kurz		87129	3
11	Lokpfeife		88002	6
12	Antenne		88030	4
13	Hauptschalter		88175	3
14	Isolator mit Loch		88176	3
15	Puffer gewölbt		88503	4
16	Universalkupplung		89282	5
17	Achse 2.6X11.5		89701	2
18	Lager für Schneckenachse		89749	6
19	Radkontakt re.		89862	4
20	Treppe		93502	2
21	Stromabnehmerauflage		94809	2
22	Stromabnehmerantrieb		97883	2
23	Kardanwelle		100260	3
24	Brückenstecker		100644	7
25	Isolator		101584	2
26	Abdeckung Digital		105346	4
27	Maschinenraum einrichtungssatz		105347	7
28	Fenster-Scheinwerfersatz		105355	15
29	Isolatorsatz		105356	18
30	Dachleitung kurz		105362	6
31	Führerstand o. Loch		106104	8
32	Kathodenfallableiter		106110	2
33	Distanzplättchen		106116	2
34	Puffertritt		106294	2
35	Haltegriff lang		106906	4
101	Haltegriff		106907	4
36	Oberleitungskontakt		107673	3
37	Schneckensatz		107798	24
38	Radsatz		107799	18
39	Radsatz mit 2 Haftringen		107800	20
40	Getriebekasten m. Zahnrad		107801	32
41	Attrappenrahmen klein		107808	3
42	Schneckendeckel mit Stab.Feder		108260	8
43	Teilesatz		108322	8
44	Drahtlampe T3/4 16V 30mA		108616	10
45	Zahnradatz		110811	8
46	Lampen-Flexplatine		112932	26
47	Platine kpl.		112933	43
48	Lichtleitersatz kpl.		112934	11
49	Zahnradatz		112936	13
50	Lichtnagel weiß		112940	2
51	Teilesatz		112941	7
52	Schraube M 1.6x6		113069	2
53	Radkontakt li.		114612	4
54	Anlaufscheibe 4x2.1x0.01		114622	2
55	Lokrahmen		114856	36
56	Gehäuse kpl. Betr.Nr. 1010.10		114857	68
57	Zurüstbeutel		114858	24
58	Mittelfenster		114859	5
59	Stirngriff kurz		114860	4
60	Blende DC		114861	10
61	Schienenräumer Satz		114862	8
62	Blendenteile Satz		114863	10
63	Kontakthalter kpl.		114869	17
64	Tafelsatz Lackiert		114913	20
Abweichende Teile 63793				
65	Stromabnehmer OBB Wanisch		85307	39
66	Schraube 2.2X6.5 = 111304		85800	2
67	Stromabnehmerantrieb		95892	5
68	Lichtnagel groß		101643	2
69	Puffertritt		105223	2
70	Abdeckung Digital		106095	4
71	Kontakthalter		106101	5
72	Stirnfenster-Scheinwerfersatz		106102	15
73	Lichtnagel klein rot		106106	2
74	Frontgriff rot		106107	3
75	Verschiebergriff		106108	2
76	Teilesatz		106109	7
77	Teilesatz		106113	11
78	Schienenräumer		106115	4
79	Dachleitung lang		106819	6
80	Grundrahmen		112931	36
81	Zurüstbeutel		112935	24
82	Stromabnehmerauflage		112938	2
83	Blende		112942	20
84	Schienenräumer		112943	4
85	Teilesatz		112945	7
86	Gehäuse kpl. Betr.Nr. 1010.005-5		114610	68
87	Lichtleitersatz kpl.		114611	11
88	Mittelfenster		114613	5
~ Wechselstrom				
89	Decoder Motorloja m. Lastregelung		10738	--
90	AC-Flüsterschleifer kurz		40064	---
91	Haftungsatz *AC*		40075	---
92	Schraube M1.6x8		85695	2
93	Getriebekasten		112946	20
94	Radsatz o. Zahnrad		112947	16
95	Radsatz mit 2 Haftringen		112948	20
96	Radsatz		112949	18
97	Radsatz		112950	18
98	Blende AC		112951	10
99	Radsatz o. Zahnrad		113848	16
100	Blende AC		114870	10

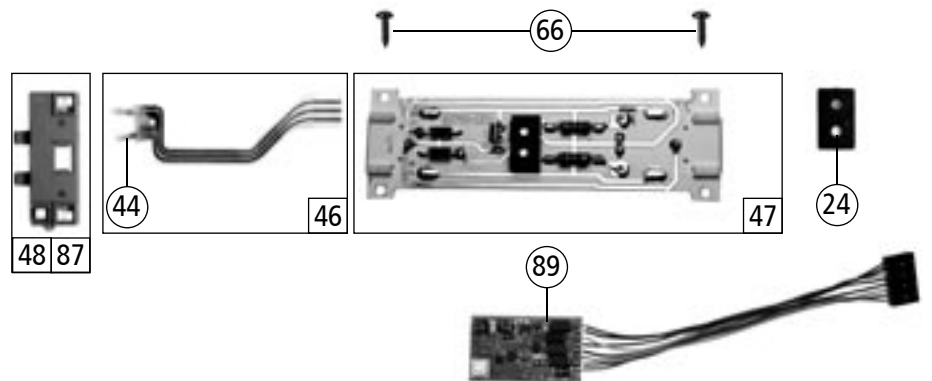

Pos.Nr. Pos.no. Position	Beschreibung Description Désignation	Preisgruppe Price bracket Catégorie de prix	Art.-Nr. Art.no. Réf.
1	Motor		85093 57
2	Pantograph		85319 39
3	Set with traction tires DC		85622 19
4	Screw M 2x5		85669 3
5	Screw M 2x8		85674 2
6	Screw 2.2x9.5		85808 2
7	Spring		86202 2
8	Worm gear		86490 4
9	Gear		86493 2
10	Cardan shell short		87129 3
11	Loco whistle		88002 6
12	Antenna		88030 4
13	Main switch		88175 3
14	Insulator with hole		88176 3
15	Buffer vaulted		88503 4
16	Universal coupling		89282 5
17	Axle 2.6x11.5		89701 2
18	Bearing for Worm axle		89749 6
19	Wheel contact right		89862 4
20	Steps		93502 2
21	Pantograph support		94809 2
22	Pantograph drive		97883 2
23	Cardan Shaft		100260 3
24	Connector		100644 7
25	Insulator		101584 2
26	Cover		105346 4
27	Engine room set		105347 7
28	Window-headlight set		105355 15
29	Insulator set		105356 18
30	Roof wire short		105362 6
31	Driver's cab without hole		106104 8
32	Cathode deflector		106110 2
33	Spacer		106116 2
34	Buffer step		106294 2
35	Handrail long		106906 4
101	Handrail		106907 4
36	Overhead supply connector		107673 3
37	Worm set		107798 24
38	Wheelset		107799 18
39	Wheelset with 2 traction tires		107800 20
40	Gearbox with gear		107801 32
41	Push in part set, small		107808 3
42	Wormcover with vibration damper		108260 8
43	Parts set		108322 8
44	Bulb T3/4 16V 30mA		108616 10
45	Gearset		110811 8
46	Flexible Printed circuit for bulbs		112932 26
47	Printed circuit assembly		112933 43
48	Light transmission set cpl.		112934 11
49	Gearset		112936 13
50	Light nail white		112940 2
51	Parts set		112941 7
52	Screw M1,6x6		113069 2
53	Wheel contact left		114612 4
54	Washer disc 4x2,1x0,01		114622 2
55	Main frame		114856 36
56	Casing assembly 1010.10		114857 68
57	Bag with accessories		114858 24
58	Window		114859 5
59	Handrail short		114860 4
60	Cover DC		114861 10
61	Rail guard set		114862 8
62	Cover accessoires set		114863 10
63	Contact holder assembly		114869 17
Variant Parts 63793			
65	Pantograph OBB Wansch		85307 39
66	Screw 2,2x6,5=111304		85800 2
67	Pantograph drive		95892 5
68	Light nail great		101643 2
69	Buffer step		105223 2
70	Cover		106095 4
71	Contact frame		106101 5
72	Front window-headlight set		106102 15
73	Light nail little red		106106 2
74	Handrail front red		106107 3
75	Scroll handle bar		106108 2
76	Parts set		106109 7
77	Parts set		106113 11
78	Pilot frame		106115 4
79	Roof wire long		106819 6
80	Main frame		112931 36
81	Bag with accessories		112935 24
82	Pantograph support		112938 2
83	Truck		112942 20
84	Pilot frame		112943 4
85	Parts set		112945 7
86	Casing assembly 1010 005-5		114610 68
87	Light transmission set cpl.		114611 11
88	Window		114613 5
~AC Wechselstrom			
89	Decoder Motorola load regulated		10738 ---
90	Whisper wiper short		40064 ---
91	Traction tires *AC*		40075 ---
92	Screw M1,6X8		85695 2
93	Gearbox		112946 20
94	Wheelset without gear		112947 16
95	Wheelset with 2 traction tires		112948 20
96	Wheelset		112949 18
97	Wheelset		112950 18
98	Cover AC		112951 10
99	Wheelset without gear		113848 16
100	Cover AC		114870 10

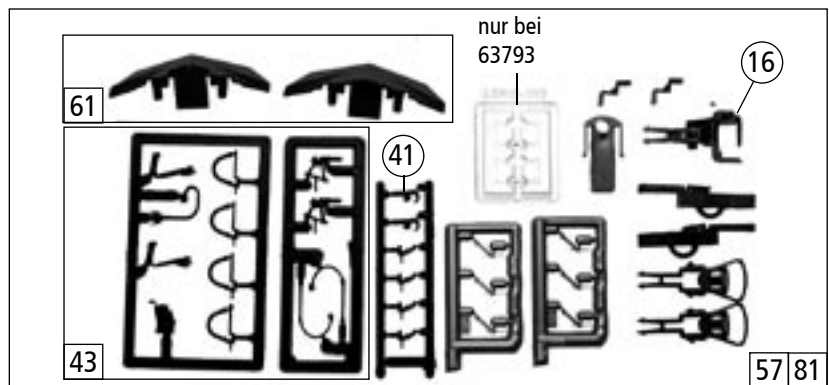
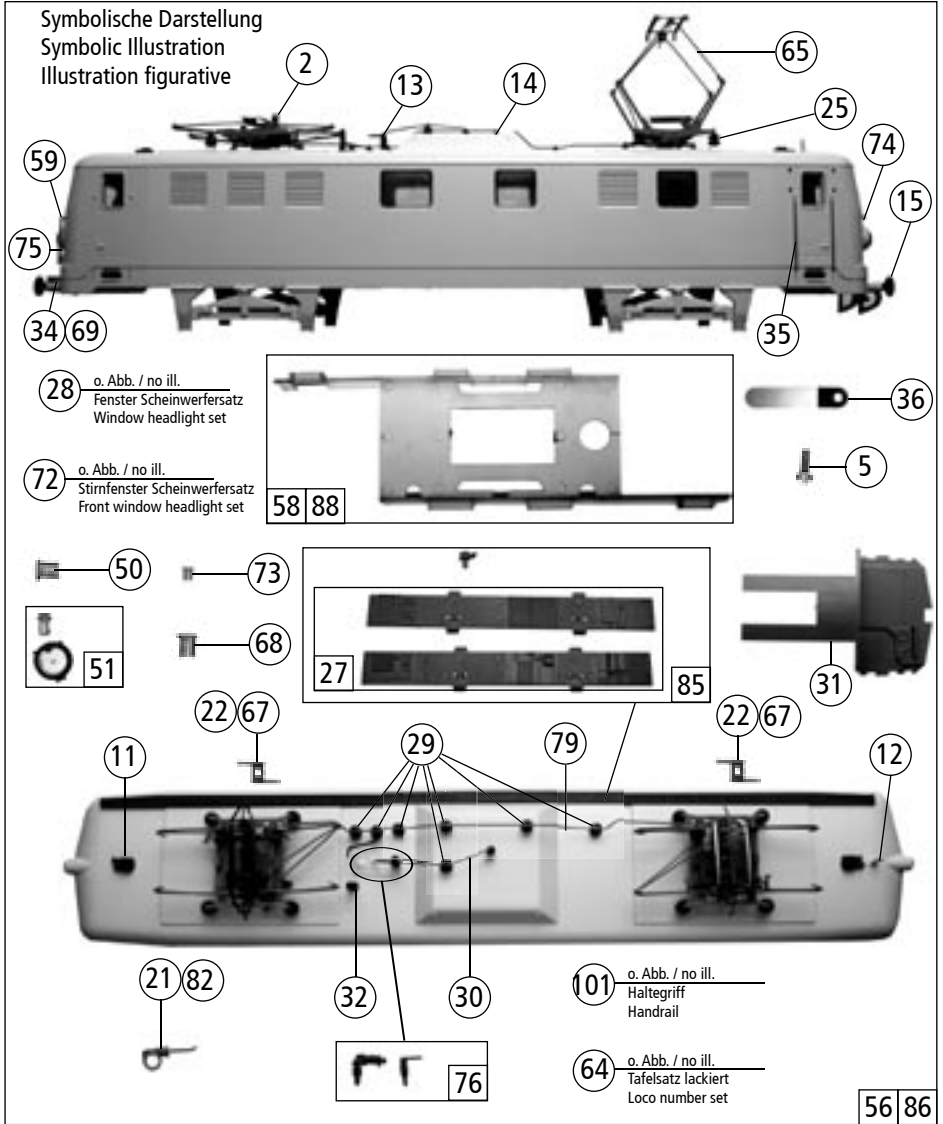
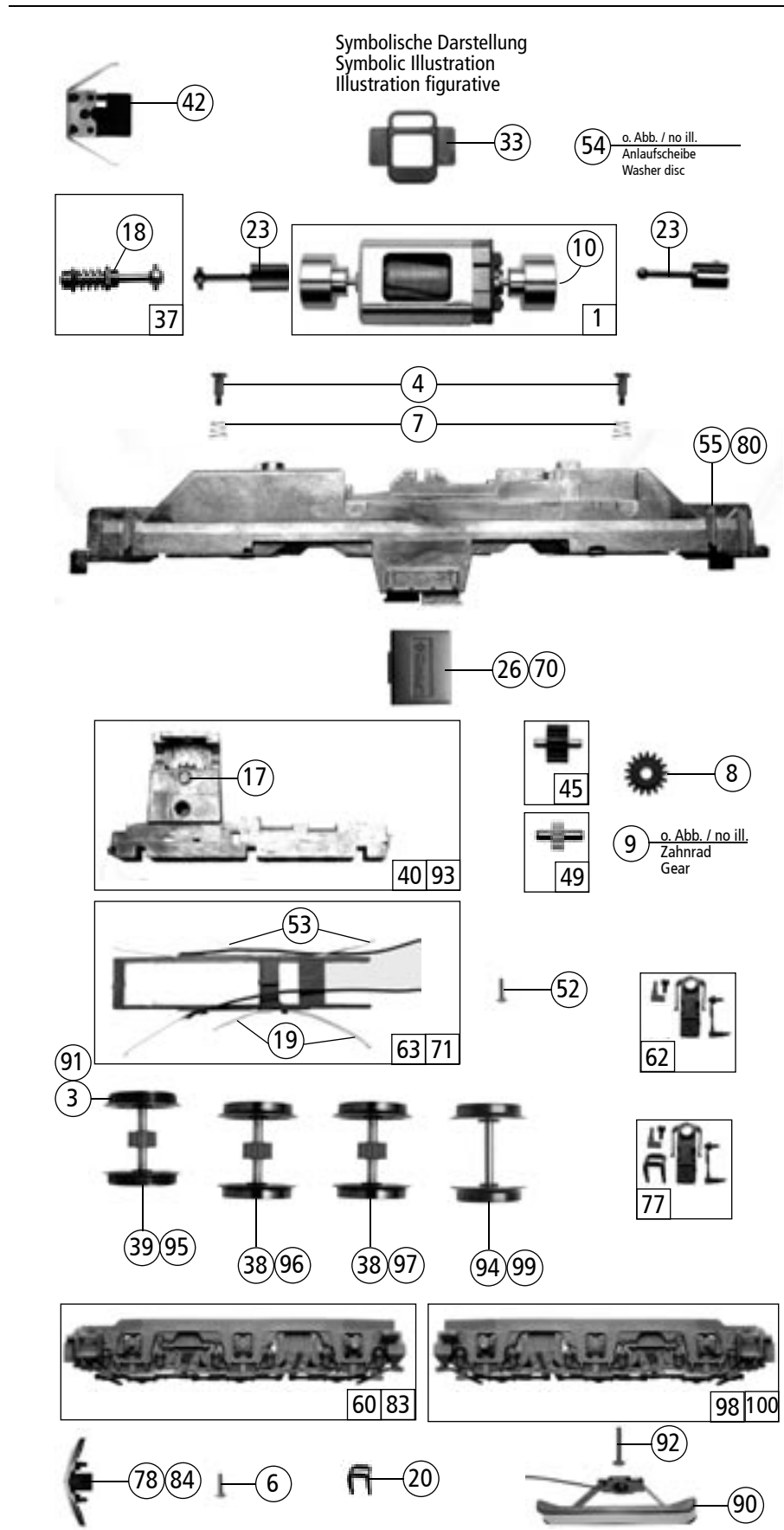

Ersatzteile erhalten Sie bei Ihrem Fachhändler, Ihrer Landesvertretung, oder bei:
You can order your Replacement Parts at your local dealer, your country representative, or:
Passez commande des pièces détachées chez votre détaillant, chez le S.A.V. de votre importateur national ou en direct au S.A.V. ROCO:

ROCO Modellspielwaren VertriebsgmbH & Co. Handels KG
— Service —
Georg-Wrede-Straße 49, D-83395 Freilassing
☎ +49 / (0)86 54 / 47 63 0
Fax: +49 / (0)86 54 / 47 63 50
E-Mail: service@roco-online.de